



DCC Layout Wiring



An Overview of DCC Components and How
to Plan and Wire a Layout for DCC

Presented by David Simmons
At the Lansing Legacies 2011
NCR Regional Convention

A copy of this presentation can be found online at: <http://ncr-nmra.org/clinics>

A Bit About Me

- 10+ years experience installing and maintaining the DCC system for the Ann Arbor Model Railroad Club
 - NCE based DCC layout
 - 100+ DCC controlled turnouts using CVP accessory decoders
 - CMR/I used for detection and signaling
 - JMRI used to integrate everything together and program decoders
- An avid Ann Arbor Railroad fan due in part to growing up alongside the tracks just North of Ann Arbor
- An N scale modeler, preferring longer trains and more space between towns to high levels of details
- Designing an AA based railroad for when the kids are out of college and moved out of the basement

Topics

- Components of a DCC System
- The 3 Busses: Control, Cab, and Track
- Determining Power Requirements
- Power Districts and Short Protection
- Common Ground
- Auto Reversers
- “DCC Friendly” Track
- Programming Track
- Mixing DC and DCC

Disclaimer

This presentation limits itself to the primary North American DCC systems that I am familiar with (NCE, Digitrax, Lenz, and CVP), however most material is generic and can be applied to other systems.

If in doubt, consult the documentation for your specific DCC system.

Basic DCC System Setup

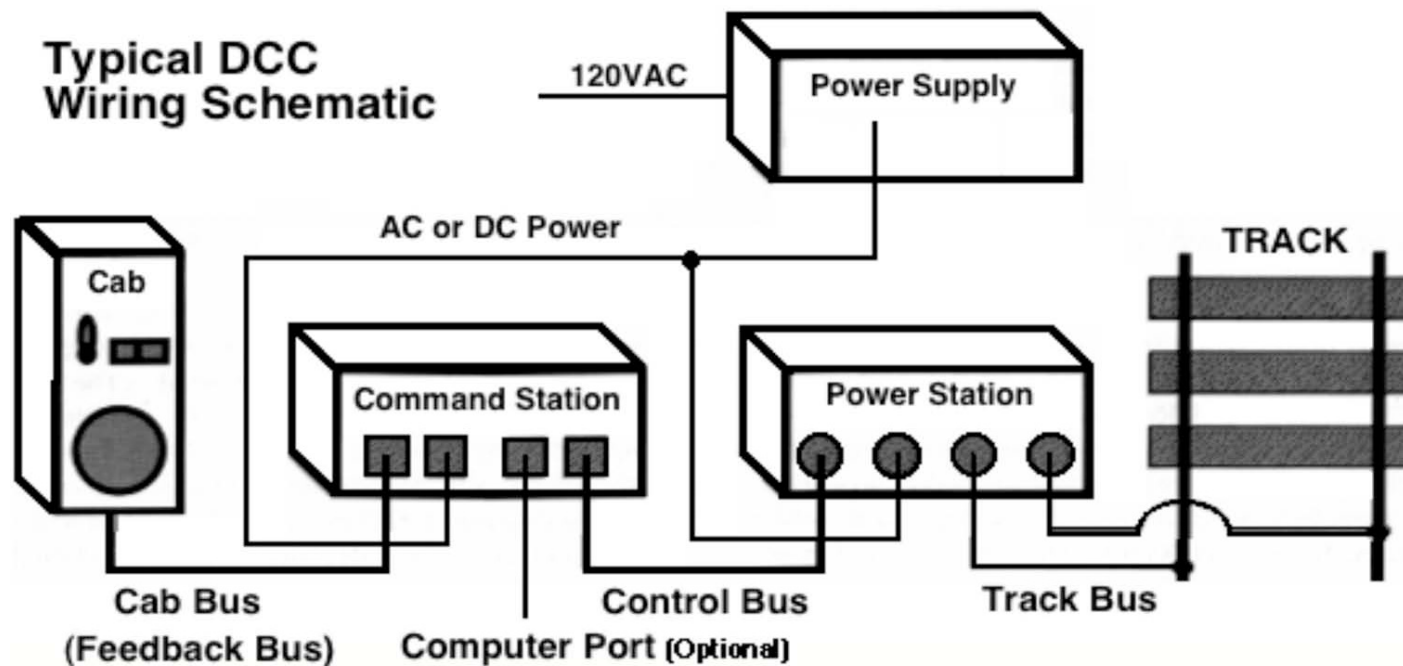

Some DCC systems integrate multiple components within a single package, yet every DCC system includes all of these features.

Advanced DCC System Setup

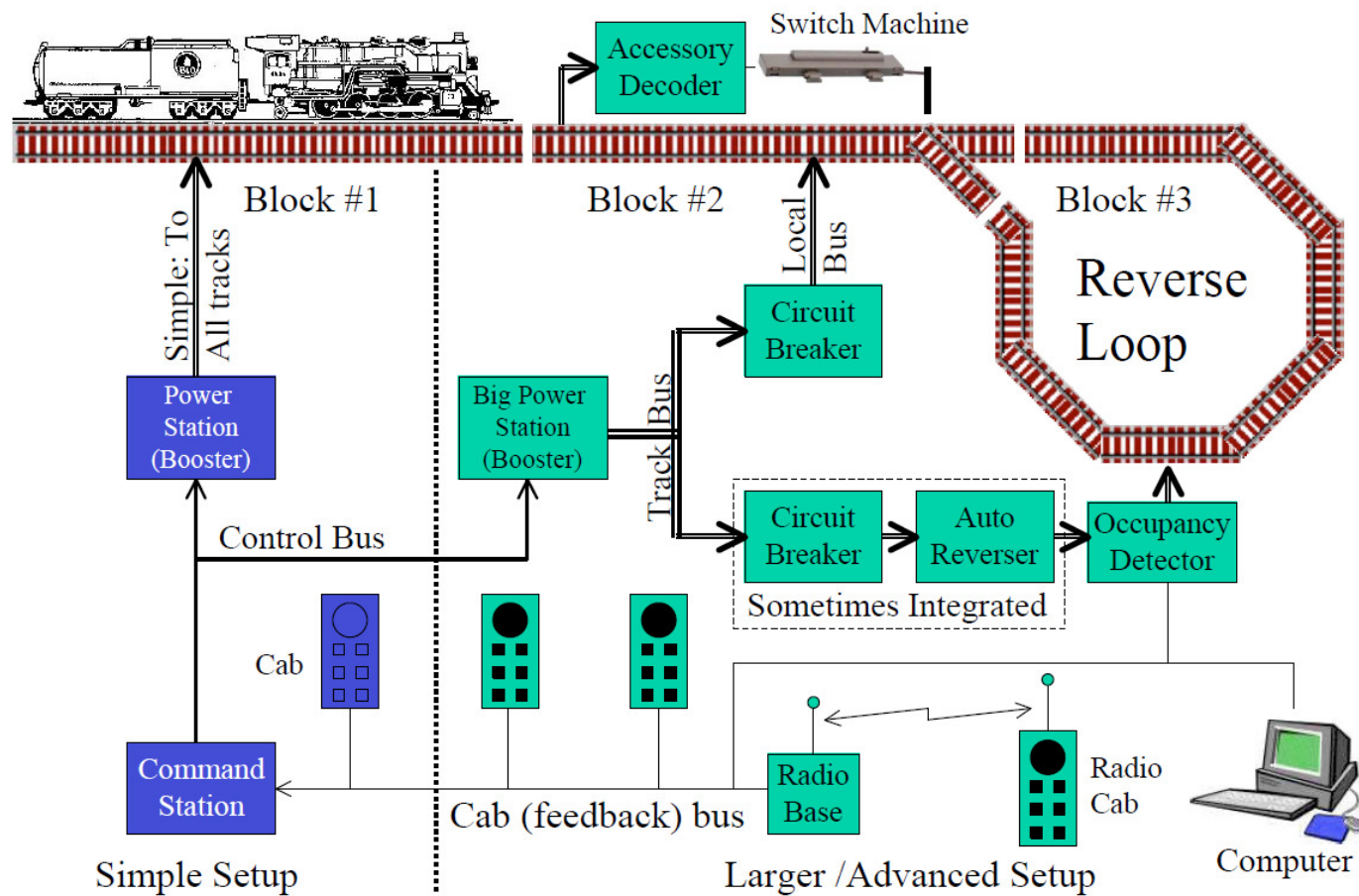

* Diagram from "DCC Layout Wiring" by Mark Gurries (<http://www.siliconvalleylines.com/dcc/2006/Wiring.pdf>)

DCC Components

- **Command Station:** Creates the DCC signal on the **Control Bus**. Also provides the **Cab Bus** connections and optional programming track and/or computer connections



DCC Components

- **Power Station:** Also called the Booster. Adds the track current to the DCC signal and puts this out on the **Track Bus**. It also provides short protection and may provide auto-reversing capabilities. Multiple boosters can be used to provide more current to your layout if needed.



DCC Components

- **Cab:** Also called Throttles. Attaches to the **Cab Bus** and provides user control of trains and accessories on the layout.



DCC Components

- **DCC Circuit Breakers:** Provide short protection after the booster. The primary reason for this is to create additional power districts so a short affects a smaller portion of the layout. These must have a lower current trip point and quicker response than your booster to work correctly.
- **Auto Reversers:** Automatically switches the power phase on the track when shorted. Commonly used on reverse loops, turntables and wyes.
- **Accessory Decoders:** Decoders that control accessories on your layout. The most common use for these are switches and signals, but many other applications are possible.

The 3 Busses

- **Control Bus:** Connects the command station to one or more boosters.
- **Cab Bus:** Connects the cabs (throttles) and sometimes other devices providing input to the command station.
- **Track Bus:** Usually refers to the wires that connect one or more boosters to the track and accessories, but also includes the track itself.
- **Note:** Digitrax “Loconet” combines the cab bus and the control bus into one bus.

The 3 Busses: Wiring & Connectors

- **Track Bus:** All systems use individual wires
- **Control Bus:** No standard for connectors, but signal on wire is the same on most systems
- **Cab Bus:** No standard, most throttles only work on one system

Brand	Atlas	Digitrax	Easy DCC	Lenz	MRC	NCE	Zimo
Cab (4 to 6 wires)	DIN	RJ12	RG58 Coax	DIN	RJ45 (Prodigy) RJH (Cmd2K)	RJ12	RJ12
Control (4 wires)	Wire	RJ12	RJ12	Wire	N/A	RJH	Wire

The 3 Busses: Control

- The DCC standard specifies the signal on the control bus.
- The DCC standard does not specify the wiring or connectors.
- You can mix most vendors boosters, but you will have to create custom cables to connect them.
- Mixing different manufacturer's boosters is not recommended unless you are reusing existing hardware.
- For modular (RJ) cables, do **NOT** use phone cables as they typically reverse the pins in the cable.
- If you make your own connectors, be sure to use proper type for either stranded or solid wires.

The 3 Busses: Cab

- There is no standard for the cab bus, each manufacturer is proprietary. You generally must use the same brand for your cab and your command station.
- The cab bus is usually a “daisy-chain” around your layout
- Many DCC systems provide a wireless cab option, but you should still plan on installing a cab bus so you can plug in if required.
- Same rules regarding phone cables applies to the cab bus.

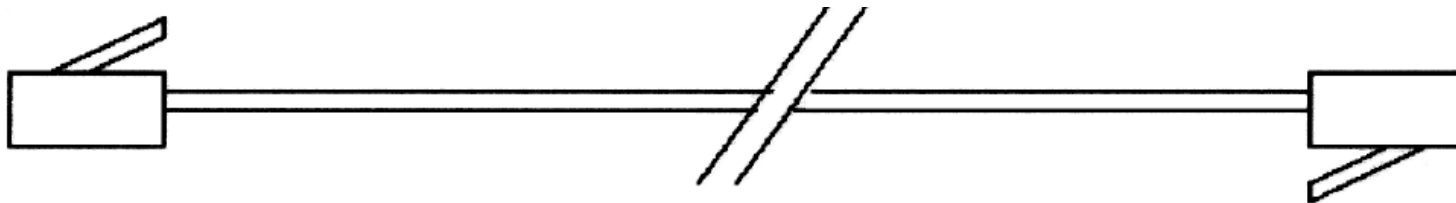

The 3 Busses: Track

- Carries electrical power to track
- Use heavy wire! This is due to voltage drop not current carrying requirements.
- Wire run length* recommendations:

Stranded Wire Size	10% V Drop 5A Booster	5% V Drop @5A 10% V Drop @ 10A	5% V Drop 10A Booster
18 AWG	20 Ft	15 Ft	7 Ft
16AWG	40 Ft	20 Ft	10 Ft
14 AWG	70 Ft	35 Ft	18 Ft
12 AWG	100 Ft	50 Ft	25 Ft
10 AWG	130 Ft	65 Ft	33 Ft

* Run length is distance **out to track and back**.

- Track feeder wire should be #18 to #24 AWG every 6' or less

Determining Power Requirements

- You need to add up the current, in amps, of all the devices powered by your DCC system. This includes:
 - Locomotives: Be aware that sound locomotives draw more power than non-sound locomotives, especially at power up.
 - Switch Machines, if you plan on using DCC powered accessories
 - Rolling stock lighting and any other special effects
 - Anything else attached to your DCC buses

Determining Power Requirements

- Total Locomotive Current Draw
 - Count the number of simultaneous operating locomotives
 - Determine motor current per locomotive
 - Don't know? Use: N=½ Amp, HO=¾ Amp, S=1½ Amps, O=4 Amps for non-sound, add about ¼ Amp for sound locomotives
 - Calculate total current
 - Example: 14 HO locos with sound x 1 Amp per locomotive = 14 Amps
- Total Rolling Stock Current Draw
 - Count the number of lights
 - For standard bulbs assume 0.030 A each, LED's assume 0.020 A each
 - Calculate total current
 - Example: 10 lighted passenger cars x 4 bulbs each x 0.030 A = 1.2 A

Determining Power Requirements

- Total Accessory Current Draw
 - Determine total current draw for all DCC powered accessories. This may include switch motors, signal lights, anything else on the DCC Bus
 - Example:
 - Switch Motors: 120 Tortoises x 0.01 A Each = 1.2 A
 - Signals: 160 LED's x 0.02 A Each = 3.2 A
 - Total Accessory Current = 1.2 A + 3.2 A = 4.4 A
- Total Layout DCC Current Draw
 - Sum of all of your current requirements
 - Example: 14 A for locomotives + 1.2 A for rolling stock + 4.4 A for accessories = 19.6 Amps

Power Districts & Short Protection

- Why Have Power Districts?
 - Short shuts down entire power district
 - Safely distribute power to the layout where needed
- Why have Short Protection?
 - High current levels are risky
 - $14\text{ V} \times 5\text{ A} = 70\text{ watts}$
 - $14\text{ V} \times 20\text{ A} = 280\text{ watts}$
 - Damage to equipment, potential fires!
- Using lamps is not short protection!
 - Only limit current flow so power district doesn't shut down.
 - $14\text{ V} \times 1\text{ A} = 14\text{ watts}$

Power Districts

- Use circuit breakers to divide booster output for multiple sub districts
 - Circuit breakers must trip at lower current than booster and faster than your booster to be effective
 - Sound locomotives are a potential problem due to large inrush current at startup. Newer electronic breakers address this issue
 - Recommended brand: DCC Specialties
- Large layouts: Use multiple smaller boosters
 - Example: Total Current 19.6 Amps / 5 Amps per booster = 4 boosters
 - Recommended: 5 boosters for extra capacity
- Recommended: If you plan on DCC powered accessories, use a separate booster for your accessories
- Always double gap between power districts

Short Protection

- All boosters have inherent short protection
- Circuit breakers reduce current potential
 - Example: 10 Amp booster with 4 Amp breakers means max current at track is 4 Amps
- Test! Test! Test!
 - Use the Quarter Test or something equivalent in larger gauges
 - Place a quarter across the rails at every piece of track
 - The booster or circuit breaker should immediately shut down the track and it should stay off until the short is removed
 - There should be no large build up of heat
 - If there is a problem here you have a wiring issue

Power Districts & Short Protection

- Example
 - 5 main power districts
 - 1 5 Amp booster for Accessories (switch motors and signals)
 - 4 5 Amp boosters for track
 - 16 sub power districts on track
 - Each booster has 4 4 Amp breakers to create power districts for the mainline, yards, and each town separately
 - Total Layout Current Capacity = 5 boosters x 5 Amps each = 25 Amps
- Why not use 2 10 Amp boosters?
 - Fault tolerance
 - Total required current was 19.6 Amps
 - N+1 would require 3x10 Amp or 5x5 Amp boosters
 - Common Parts: Accessory and Track used same boosters

Common Grounds

- If you have multiple boosters, you must have a single “common ground”!
- Two types:
 - Common Rail
 - Very common in older layouts
 - One side of the track bus on each booster is wired together
 - Must maintain proper phase so as to prevent voltage doubling
 - Not all boosters support it! Check manufacturer documentation
 - Home Ground
 - Recommended for new layouts
 - Wiring together of the booster common, usually by a ground point on the booster chassis
- Do not use an “Earth ground”!

Common Grounds

- Common Rail: Determining the phase
 - Measure the voltage between 1 wire of 2 boosters.
 - If 0 volts, boosters are in phase
 - If not, switch wires on one of the boosters and measure again

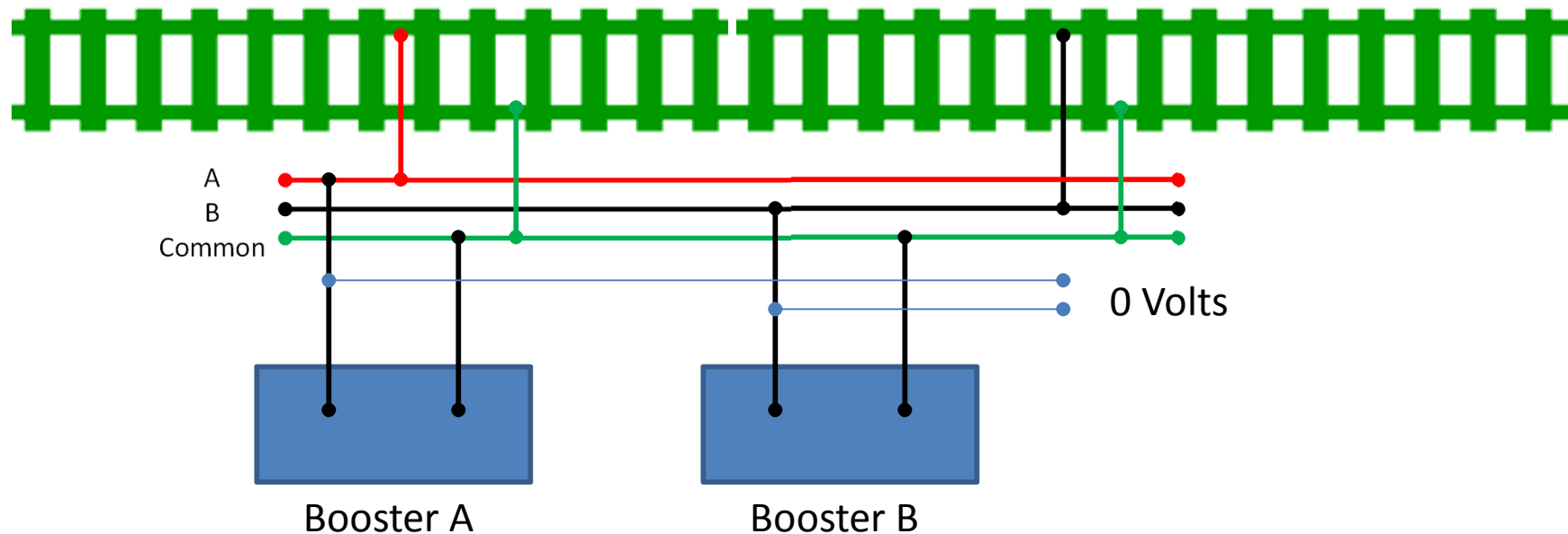

Common Grounds

- Booster Common: Phase doesn't matter
 - Ground between boosters should be heavy wire to carry full current.
 - Recommended 10 or 12 AWG wire

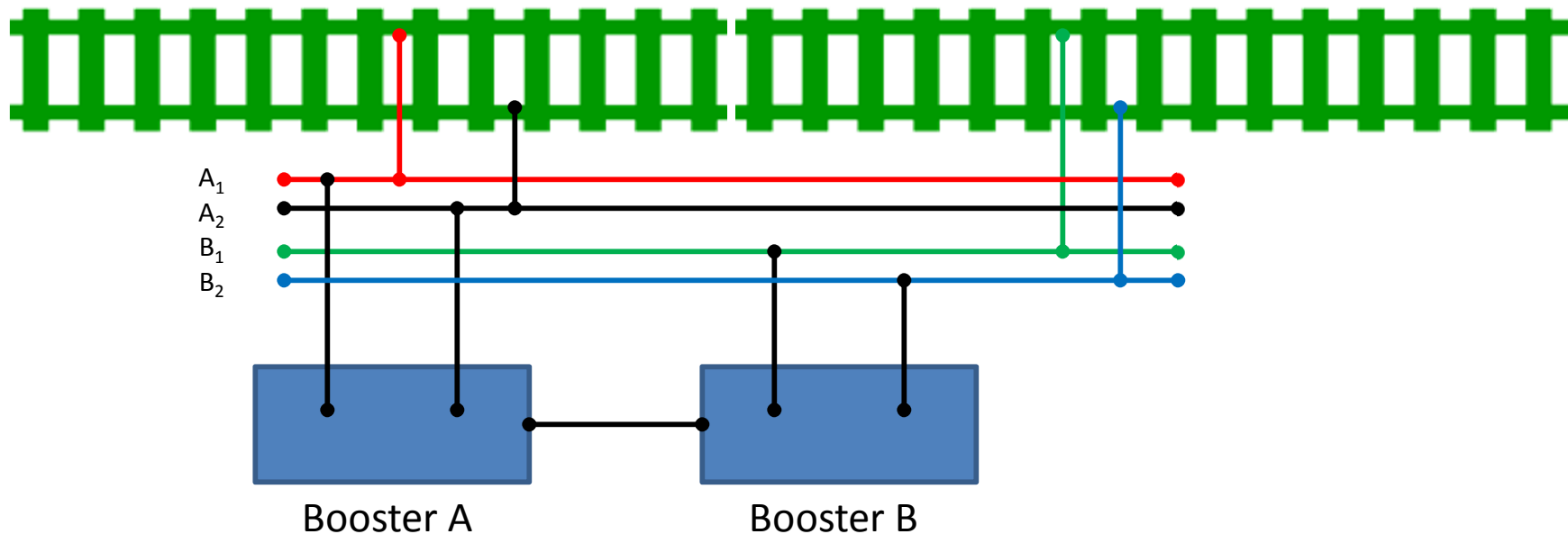

Auto Reversers

- Reverses the power phase on the track automatically when a short is detected
- Reversing block should be longer than longest train
- Commonly used where trains are turned somehow
 - Reverse loops
 - Turntables
 - Wye's
- They are optional, other methods include
 - Manual toggles
 - Contacts on switch machines
 - Gaps in turn table rails
 - Disadvantages:
 - Require manual control
 - Sound locomotives will often reset

Auto Reversers

- Two Types
 - Relay (MRC primarily)
 - Older style
 - Advantage: Cheaper
 - Disadvantage: Slower, booster may trip first, sound locos may reset
 - Electronic (most others)
 - Most manufacturers now use these
 - Advantage: Very fast, recommended with sound locomotives
 - Disadvantage: More expensive
- Recommended Brand: DCC Specialties
 - Work very well with sound locomotives

“DCC Friendly” Track

- What does “DCC Friendly” mean?
 - Track power is always on
 - Potential for shorts is minimized
 - Primarily used when discussing turnouts
- “DCC Friendly” is a goal, not a requirement
- For existing layouts, if your track works well in DC, it will work fine in DCC

“DCC Friendly” Track

- What is a “DCC Friendly” turnout?
 - Atlas, Kato, Roco, the new Micro Engineering, Shinohara Walther's turnout

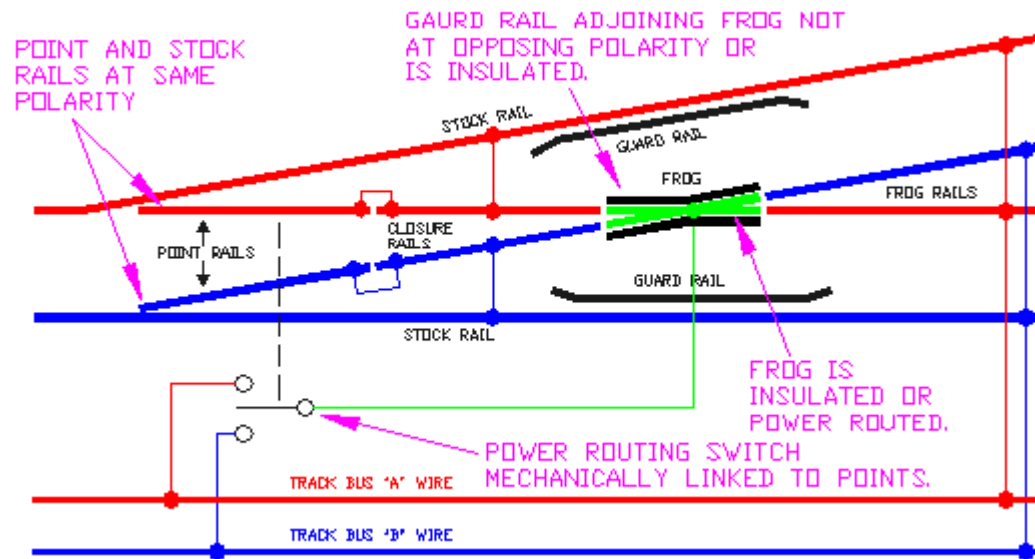

Diagram from “www.wiringfordcc.com”

“DCC Friendly” Track

- Not 100% “DCC friendly”, but easy to make so
 - Peco and Tellig are this type
 - Use gaps or insulated joiners at rails leading from frog

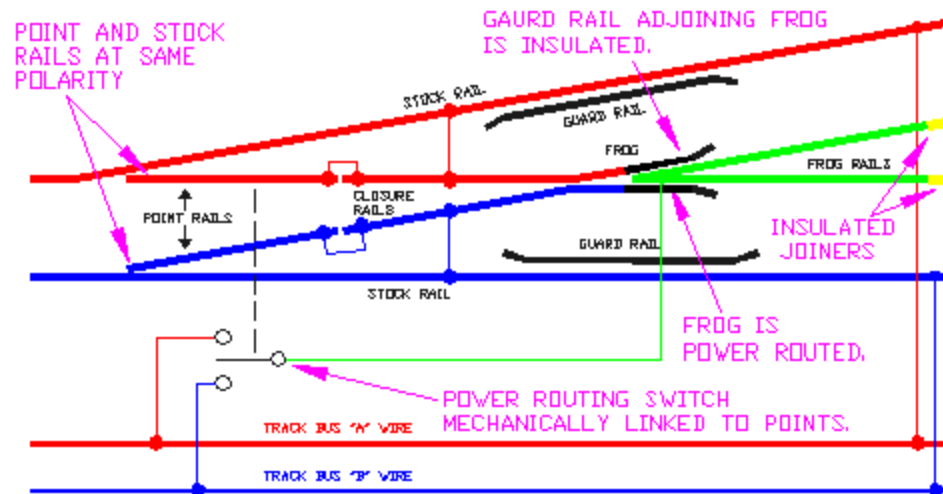

Diagram from “www.wiringfordcc.com”

“DCC Friendly” Track

- Not “DCC friendly,” lots of effort to make so
 - BK Enterprises, Old style Micro Engineering, Shinohara and Walthers
 - Biggest issue with longer steam locomotives

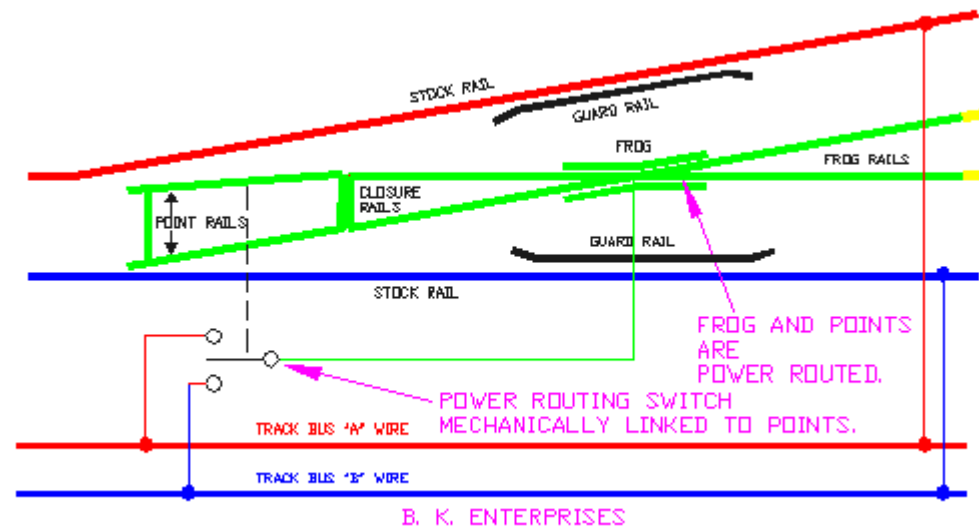

Diagram from “www.wiringfordcc.com”

Programming Track

- Used to program and read back DCC Decoders
 - Low current output
 - Test new decoder installs here, a short is less likely to damage decoder
- Must be isolated from the railroad
- If you use an on-layout programming track, be sure to electrically isolate it
 - Use a quad-pole, double throw switch

Programming Track

Running Mode:

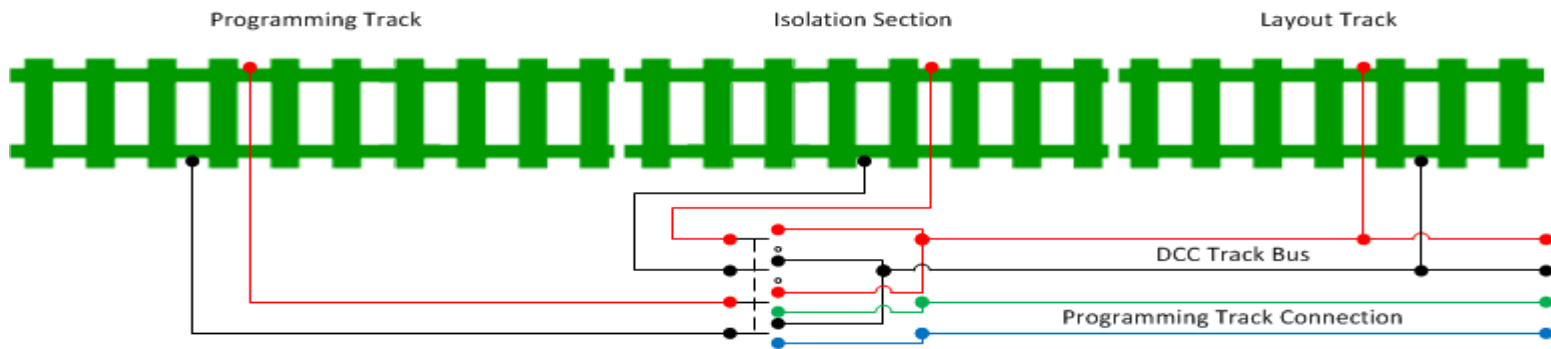

Programming Mode:

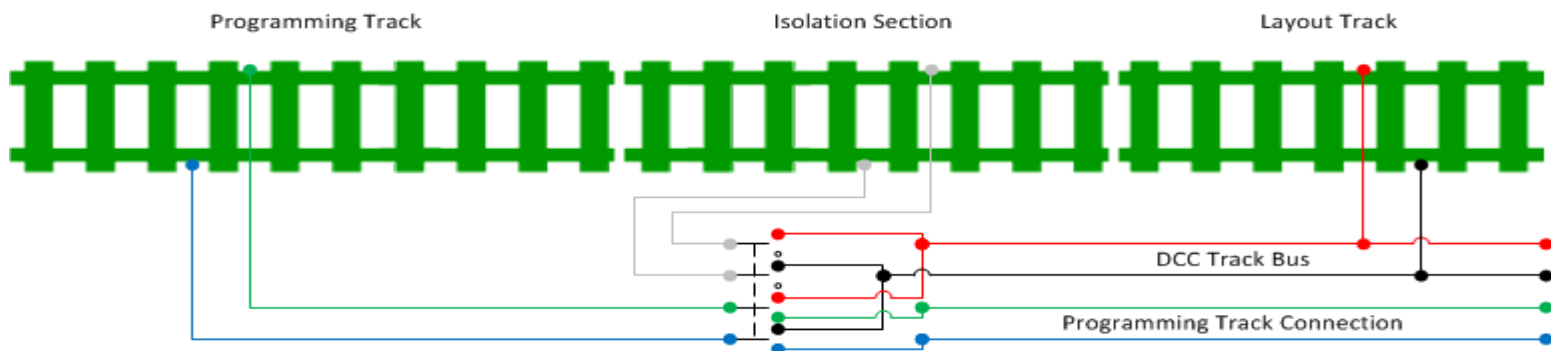

Mixing DC and DCC

- It is not recommended to mix DC and DCC on a layout
- If they are bridged, usually the DCC equipment loses
- If you want to run DC and DCC use one or the other on entire layout

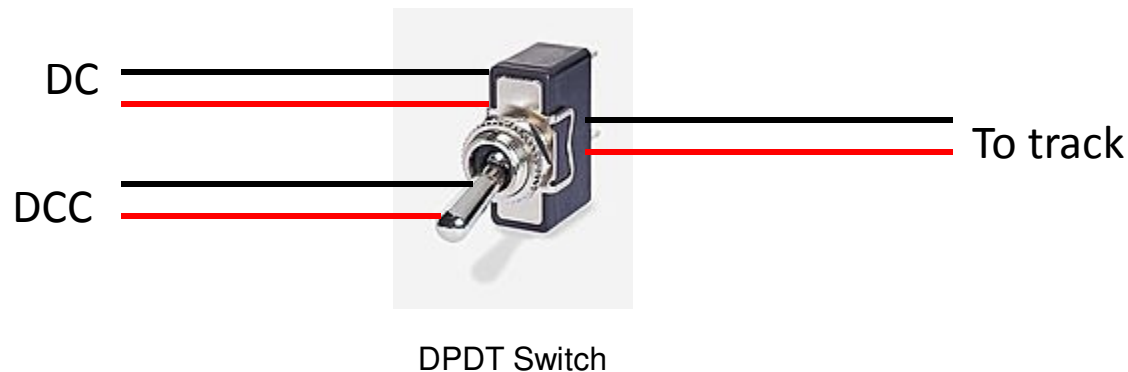

Questions?

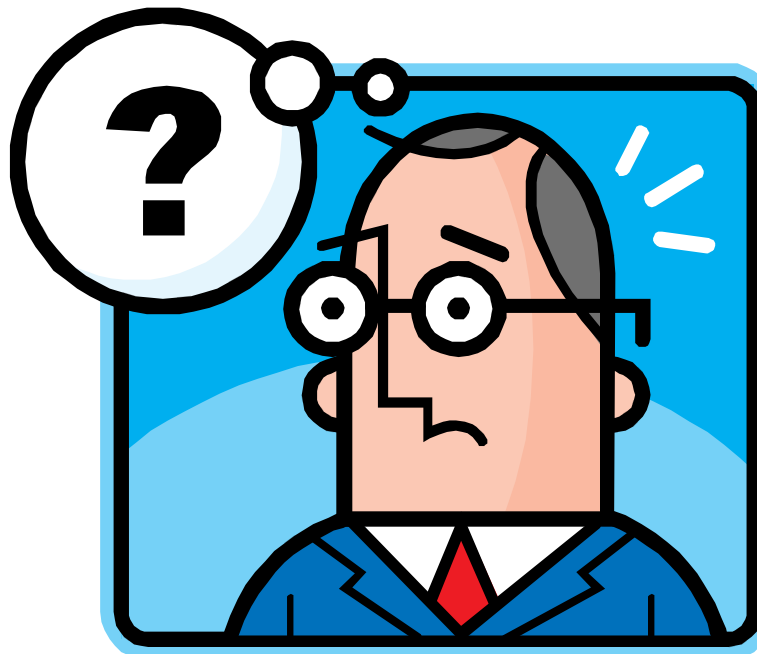

A copy of this presentation can be found online at: <http://ncr-nmra.org/clinics>

Additional Resources

- Allan Gartner's "Wiring for DCC" Site
 - <http://wiringfordcc.com>
- "DCC Wiring" by Marcus Gurries
 - <http://www.siliconvalleylines.com/downloads/dccwirin.pdf>
- "The Digitrax Big Book of DCC" by Digitrax
- "The DCC Guide" by Kalmbach

